

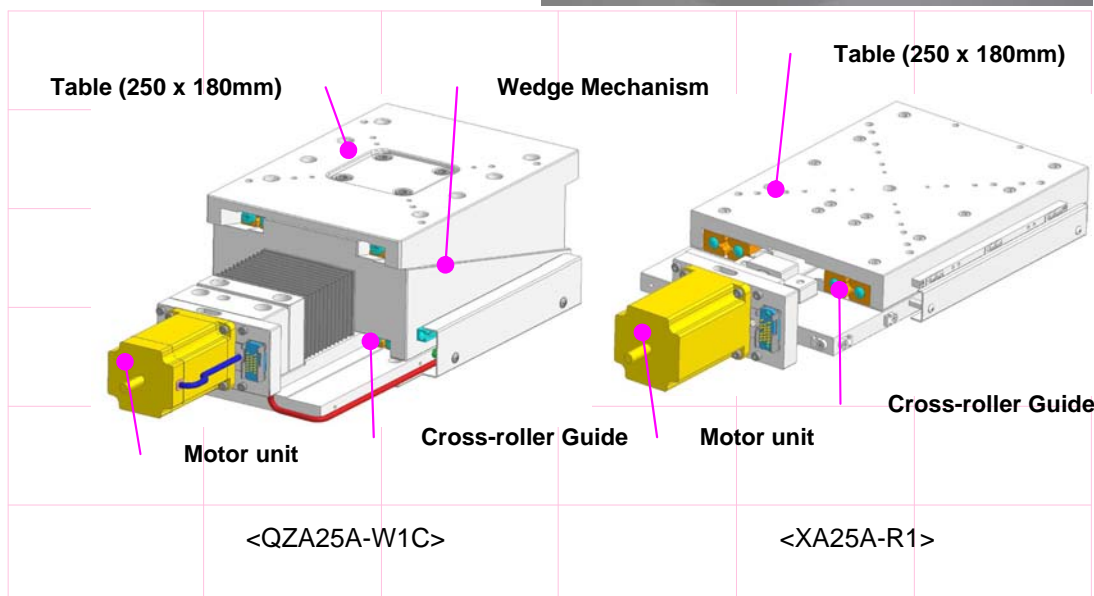

High-Load X & Z Stage <QZA25A-W1C & XA25A-R1>

This picture shows the assemble of Z stage QZA25A-W1C on X stage XA25A-R1.
These stages have the high load capacity.



Features

- ◆ The high-load capacity X and Z stages.
- ◆ The strength is remarkable.
- ◆ With 1 mm reading scale.
- ◆ It is consisted of 2 reliable Kohzu's standard stages.
- ◆ Many orientations assembling is possible.
- ◆ Table size : 250 x 180 mm
- ◆ 5-phase stepping motor

Specifications

Model	QZA25A-W1C	XA25A-R1
Stroke	±10 mm	±50 mm
Lead Mechanism	¼-Wedge with Ground Screw, Pitch 1.0mm	Ground Screw, Pitch 1.0mm
Resolution (half-step)	0.25 μm	1 μm
Maximum Speed	2.5mm/sec	10mm/sec
Repeatability	<±0.5 μm	<±1 μm
Straightness	<10 μm / 20mm	<4 μm / 100mm
Load Capacity	50 kg	40 kg
Dimension (mm)	498 x 199 x 130 (length x width x height)	444 x 198 x 45 (length x width x height)
Self Weight	25 kg	8.5 kg

Kohzu Precision Co.,Ltd.

Tel: +81-44-981-2131

Fax: +81-44-981-2181

Email:sale@kohzu.co.jp

URL://www.kohzuprecision.com